

X1 STEALTH GEN 3

User Manual

CYC MOTOR LTD
support@cycmotor.com



TABLE OF CONTENTS

SAFETY & PRECAUTION..... 3

- General Safety 3
- Before the Ride 3
- Installation & Use 4
- Disclaimer 4
- Warning..... 5

TECHNICAL SPECIFICATIONS..... 6

- Description 6
- General 6
- Motor..... 6
- Controller..... 6
- Gearbox 7
- Parts List 8
- Dimensions 10
 - BSA Threaded 68/73/83mm Version..... 10
 - BB92 Version..... 11

INSTALLATION 12

- Required Tools 12
- Operating Notice 13
- Mounting Options for Controller 13
- Adjusting the Width of the Bottom Bracket 13
- Installation of 68/73/83mm version 15
- Installation of BB92 version 18
- Mounting the Hanger 22
- Wiring & Connection..... 24

MOBILE APP & DISPLAY..... 25

GENERAL MAINTENANCE 26

- Torque Requirement for Bolts 27
- Bolt Specifications 27



WARRANTY.....28

PURCHASES FROM A CYC DEALER.....28

CONTACT INFORMATION.....28

PRIVACY POLICY.....29

INFORMATION AND COLLECTION USE.....29



SAFETY & PRECAUTION

General Safety

Kindly read through the entire user manual. This manual contains important information to reduce user risk as well as instructions for this product's proper use. Do not discard the manual but keep it for reference.

Note that your personal safety remains your responsibility and that the user must contact CYCMOTOR LTD or their official product dealer/distributor directly for any further guidelines or assistance.

Never interfere with the movable parts when the drive unit is connected to a power supply. This could result in serious injury if the system is accidentally engaged.

This product is a powerful motor system that is dangerous for children and must be handled by an adult at all times. Small components and accessories may also present a choking hazard. Keep the motor system and accessories out of reach from children.

All components and accessories may only be replaced with identical components directly supplied by CYC MOTOR LTD or an official product dealer/distributor. CYC MOTOR LTD cannot be held liable for any damages as a result of using unapproved parts.

This product only complies with local, state, and federal regulations if speed limits are set accordingly. Ensure that you have set up your X1 Pro kit according to your local, state, and federal regulations when using and registering this drive unit on a public road/area.

Before the Ride

Ensure that the drive unit chain has the proper tension. Incorrect tension could cause jamming of the system and result in injury while riding. Inspect the chain tension regularly.

Ensure that the chains are properly lubricated. Cleaning and lubricating your chain with a regular bicycle chain cleaner, is advised regularly.

When plugging in your kit, please ensure that your peripherals are connected properly as faulty connection could result in damage of the controller or batteries.



Inspect all electrical wires and plugs for damage regularly.

Secure all wires properly. Ensure that the throttle can be twisted freely without friction and that the throttle can return to its original position without restriction. This is to prevent any uncontrolled response of the system.

Installation & Use

Do not install anything other than the parts and accessories that came with this drive unit. Doing so could damage the product.

The drive system can be activated and deactivated by holding down the ON/OFF button of the display.

Avoid changing the bike gear (note: this is different from the drive unit's assist level) while the drive unit is powering the bike. This may lead to excessive wear on the chain and chain rings or other gear related failure. When changing gears, use human input only. After the gear is changed, you may accelerate again with the throttle or continue using the PAS.

Take off with the appropriate assist level and bike gear.

This product is **splash proof** and **rain proof** but not waterproof. Do not submerge it underwater.

Disclaimer

If you require any more information or have any questions about the user manual disclaimer, please feel free to contact us via email at support@cycmotor.com or call +852-3690-8938.

All the information contained in this manual is published in good faith and for general informational purposes only. CYC MOTOR LTD does not make any warranties about the completeness of this information and encourages further inquiries if needed. CYC MOTOR LTD will not be held liable for any losses and/or damages in connection with the use of this product. **The use of this product is at own risk.**



Please contact CYC MOTOR LTD if you are unsure about the assembly instructions or for any further assistance as CYC MOTOR LTD will be held liable for any losses and/ or damages created by the assembly.

The control unit's hardware and software are under the GPL V3 open-source license. VESC® is a trademark of Benjamin Vedder. More information can be found at www.gnu.org/licenses/gpl-3.0.html. CYCMOTOR LTD's source code can be found at www.github.com/CYC-MOTOR. Different firmware can be loaded to this controller.

Warning

Any issues with this product's performance or damages sustained to the product as a result of loading unauthorized firmware, will not be supported, or warranted by CYCMOTOR LTD or any authorised product dealer.

Modifications of any kind is not advised. Any issues with this product's performance or damages sustained to be the product as a result of modifications will not be supported or warranted by CYCMOTOR LTD or any authorized product dealer. If the product or its components have been found to be modified, warranty of the product may be limited in the case where troubleshooting and/ or replacement may be needed.



TECHNICAL SPECIFICATIONS

Description

This product is a high-powered electric bike (ebike) drive unit kit which includes a programmed control unit and peripherals. This product is designed to be installed as a conversion system to convert standard bicycles into electric bicycles.

General

Rated Nominal Voltage	36V – 52V
Max. RPM (at crank)	>300 RPM
Rated Power	1500W
Max. Torque (at crank)	150 N.m.
Colour	Anodized Black
Weight of Motor & Controller	2.7 kg
Total Weight with Crankset & BB	4.5 kg
Bracket Materials	7075-T6
Crank Arm Length	165mm or 175mm
Q Factor	190mm
Control Method	FOC
Motor Sensor	Hall & Temp. Sensor
Chainring	32T with 52T motor chainring 38T with 63T motor chainring
Compatibility	68-83mm, BB92, BB30/PF30 (compatible with adapter)

Motor

Motor Type	BLDC Out-runner
No-load Motor Kv	150
Stator Lamination	0.2mm
Magnet	N45UH (>180 °C)
Efficiency (at 2N.m.)	➤ 93%
Peak RPM	12,600 RPM at 84V
Epoxy sealed	Black Epoxy Potted Stator

Controller

Type	CYC X6 Controller
Nominal Voltage	36V – 72V
Max. Input Current	65A
Bluetooth	Connectivity via speed sensor
Mobile App	CYC Ride Control App for iOS & Google Play









Mounting Position	Integrated between bottom bracket / mounted separately
--------------------------	---

Gearbox

First Stage Reduction	Hardened steel sun & ring gear with brass planetary gears
Second Stage Reduction	219H Chain
Overall Reduction	1:28.9 (11/53T) 1:34.4 (11/63T)



Parts List

<p>X1 Stealth Gen 3 Motor Assembly with Chainring & controller</p>	
<p>SW102 or DS103 Display</p>	
<p>Thumb, Half-Twist or Full Throttle</p>	
<p>Magnetic Bluetooth Speed Sensor</p>	
<p>Bottom Bracket Spacers</p>	
<p>Spindle Spacers</p>	
<p>BB92 to BSA adapters</p>	
<p>Crankarms with Crankarm Bolts</p>	
<p>Left Adapter Plate</p>	
<p>Left Bottom Bracket Cup</p>	



<p>Mounting Hanger</p>	
<p>Retaining Lock Ring</p>	
<p>Spindle</p>	
<p>(OPTIONAL) Magnetic Brake Sensors</p>	
<p>(OPTIONAL) Controller Extension Wires</p>	



Dimensions

BSA Threaded 68/73/83mm Version

A	74mm
B	201mm
C	140mm
D	135.5mm
E	165mm
F	81.4mm
G	52.4mm
H	83mm
I	47.5mm
J	55.6mm
K	70.59mm
L	81.9mm
M	91.6mm
N	107.1mm

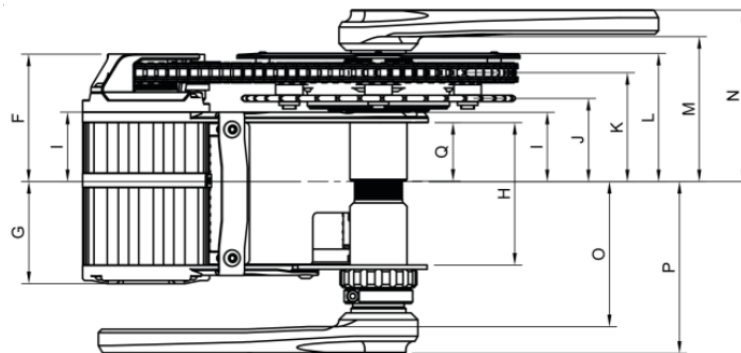
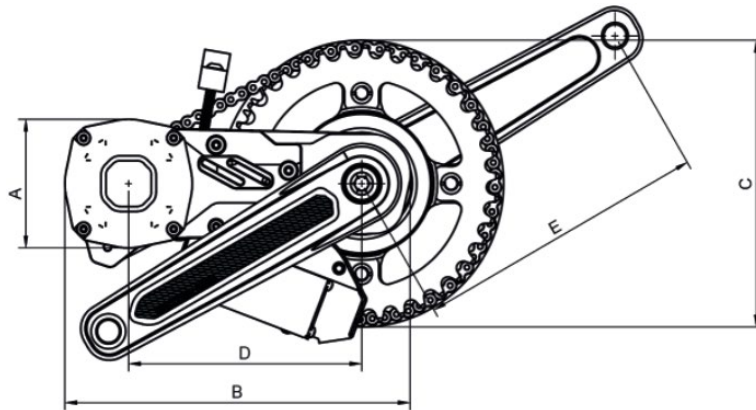



Dimensions

BB92 Version

A	74mm
B	201mm
C	165mm
D	135.5mm
E	170mm
F	77.92mm
G	55.9mm
H	92mm
I	53mm
J	61.1mm
K	76.1mm
L	87.4mm
M	97.1mm
N	112.6mm

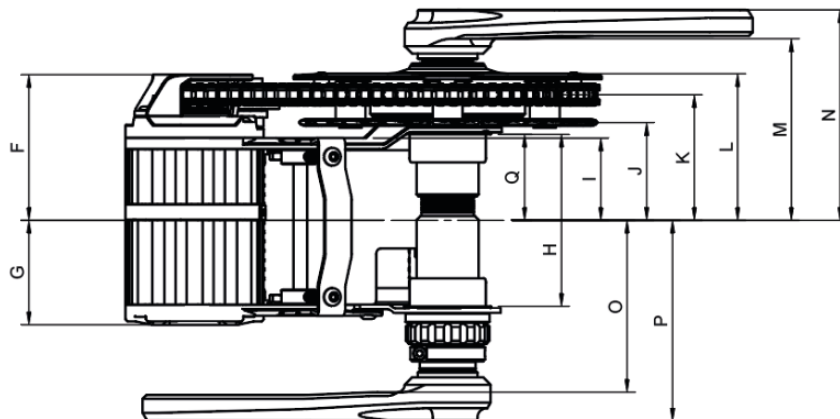
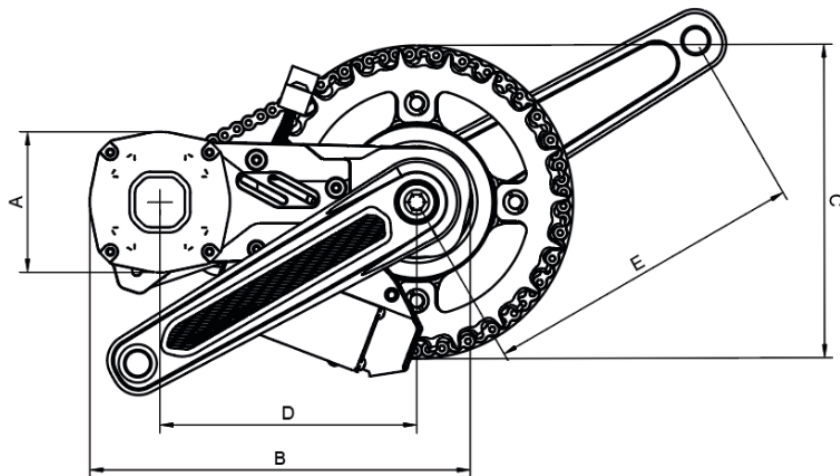



INSTALLATION

Required Tools

<p>Hex Keys (3mm & 8mm)</p>	
<p>Adjustable Wrench</p>	
<p>PressFit Bottom Bracket Removal Tools (Only for BB92 version)</p>	
<p>16 Notch Bottom Bracket Tool</p>	
<p>Crank Puller (for disassembly)</p>	



Operating Notice

RIGHT-HAND and LEFT-HAND sides are determined by the bike handle; Right-hand corresponds to the right handle.

Mounting Options for Controller

The CYC X6 controller can be mounted below the bottom bracket (pre-assembled by default) or mounted elsewhere on the bicycle frame at the user’s discretion using controller extension wires that can be selected upon purchase or bought separately from the CYC online store or an authorized dealer.

NOTE: The controller comes preassembled at the bottom bracket between the mounting plates.

Adjusting the Width of the Bottom Bracket

In order for the CYC kit to fit on various different widths of bottom brackets, there are several spacers that come with the kit. These spacers are designed to provide the bottom brackets with necessary spacing between the motor brackets.

Please note that the spacers can be adjusted to accommodate different chainlines as needed.

The preferred mounting set-ups are shown on the next page for 68mm and 73mm bottom brackets.

Before you begin, ensure that you have removed the original crank set and bottom bracket from your frame. This includes any bearings and/or cups that might have been fitted previously. To install your CYC kit, you will need a clean bottom bracket shell on your frame.

BB Version	Q Factor	Chainline	Spacer on Left	Spacer on Right	Center Offset
BSA 68mm	200	50.3	5 + 7	3	-0.1
BSA 73mm	200	49.8	3 + 7	0	-0.6
BSA 83mm	200	54.8	0	0	4.4
BB92	200	59.3	3 + 3	0	0.1



*68mm bottom brackets require a 7mm and a 5mm spacer on the left (non-drive side) and a 3mm spacer on the right (drive side) as shown.

*73mm bottom brackets require a 7mm & 3mm spacer on the left (non-drive side) and no spacer on the right (drive side) as shown.

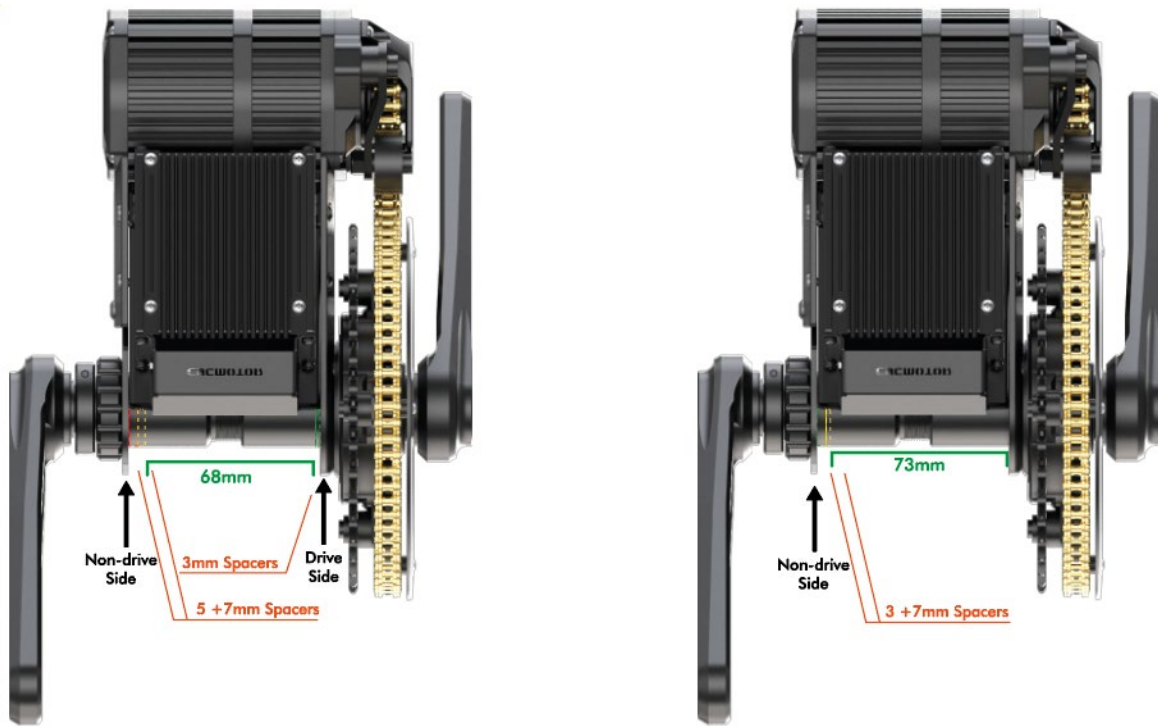



Installation of 68/73/83mm version

1. Line up the motor body with your frame at the bottom bracket, place the bottom bracket spacers accordingly (if applicable) and insert the right (drive) side of the motor into the frame's bottom bracket shell.
 - a. For a 68mm bottom bracket shell, place the 3mm bottom bracket spacer over the right (drive) side bottom bracket cup before inserting it into the frame's bottom bracket shell.
 - b. For a 73mm & 83mm bottom bracket shell, there is no need to add any bottom bracket spacers on the right (drive) side.
 - c. Note that the spacer/s can be added as needed. The above spacer placing directions are guidelines only.

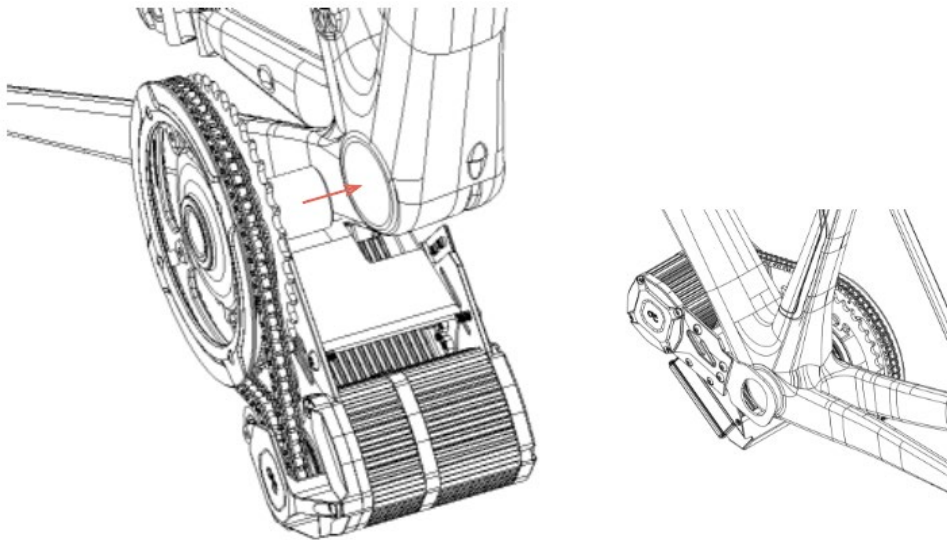

2. Add 2 x M5*6 screws into the left (non-drive) side adapter bracket and the mounting bracket.
3. Line up the 3, 5, and/or 7mm bottom bracket spacer/s provided inside the adapter bracket plate on the left (non-drive) side of the frame. Thread the left (non-drive) side bottom bracket cup into the frame's bottom bracket shell through the spacer/s and the adapter bracket plate. Add *Loctite 243* before installation. Rotate clockwise but **do not tighten fully yet.**

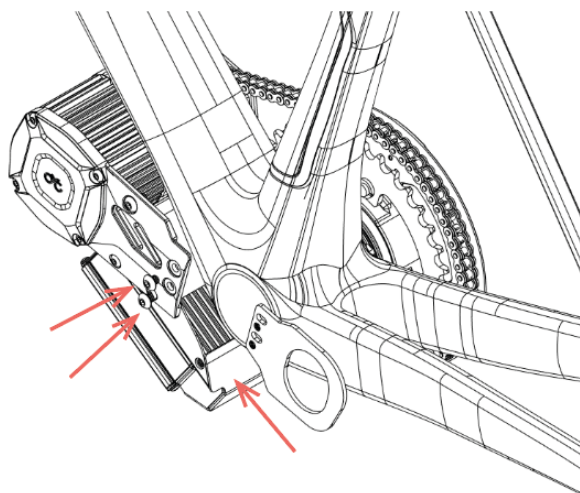



- a. For a 68mm bottom bracket shell, place the 5mm & 7mm bottom bracket spacer over the left (non-drive) side bottom bracket cup before inserting it into the frame's bottom bracket shell.
 - b. For a 73mm bottom bracket shell, place the 3mm & 7mm bottom bracket spacer over the left (non-drive) side bottom bracket cup before inserting it into the frame's bottom bracket shell.
 - c. For an 83mm bottom bracket shell, there is no need to add any in any bottom bracket spacers on the left (non-drive) side.
4. Add the 5mm bottom bracket spacer provided outside the adapter bracket plate on the left (non-drive) side of the frame. Thread the left (non-drive) side bottom bracket cup into the frame's bottom bracket shell through the spacer and the adapter bracket plate. Add grease on threads before installation. Rotate clockwise.

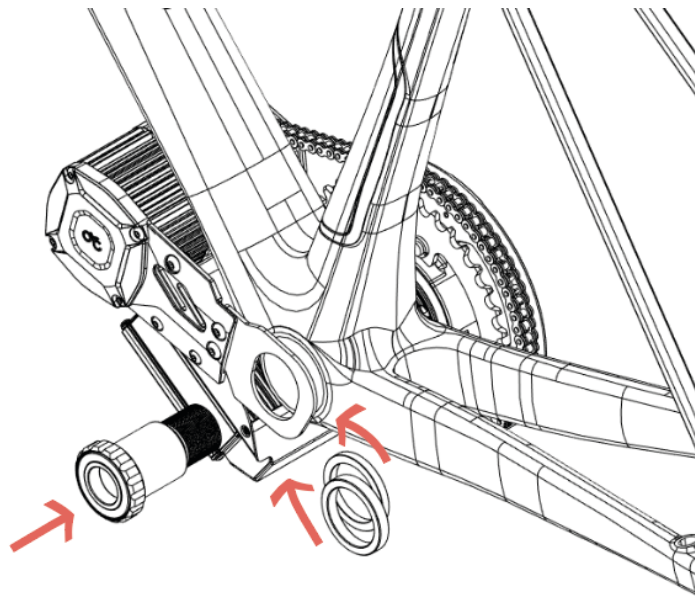

5. Insert the spindle from the right (drive) side. Note that you will need to line up the splines with the chainring assembly. If your spindle does not go through or comes to a hard stop

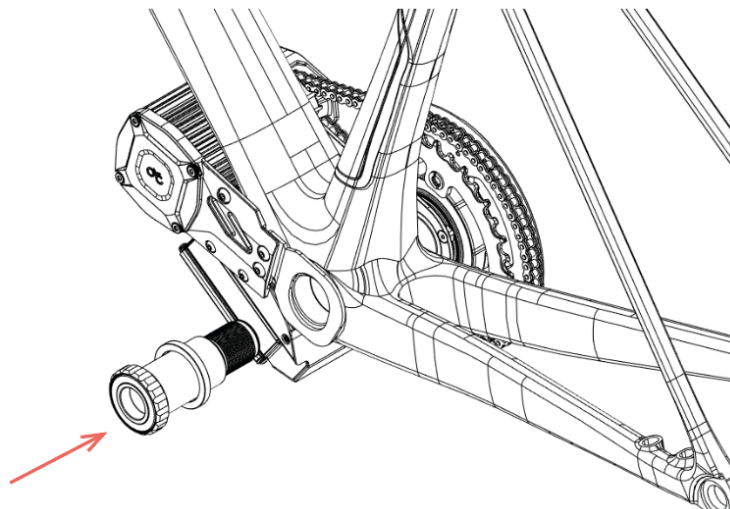

before being fully inserted, rotate the spindle a bit and try again. Once the spindle is lined



up, a soft tip hammer may also be used to get the spindle all the way through. Add a little grease on the rings and the torque sensor splines.

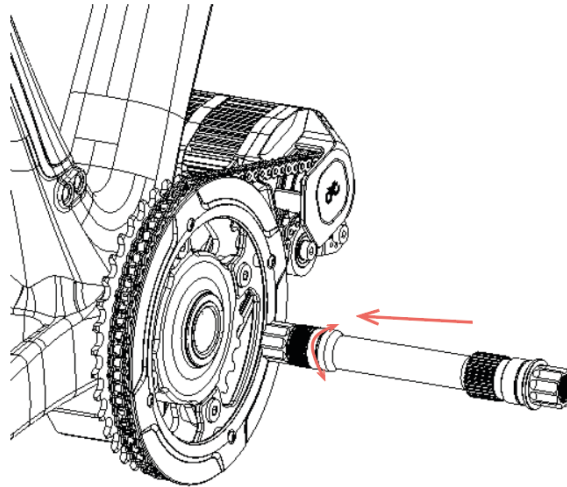

6. Install the motor hanger (see page 23) and place the rubber padding provided in between the motor and the frame.
7. Install the left (non-drive) and right (drive) side crank arm according to the L and R indication on your crank arms. Place the spindle spacer in between the left (non-drive) side crank arm and the lock ring before installing the crank arms. Use the M15 ISIS crank arm screws to tighten and secure the crank arms.
8. Ensure you hand tight and check the spindle that it can rotate freely, and the spindle doesn't have play.

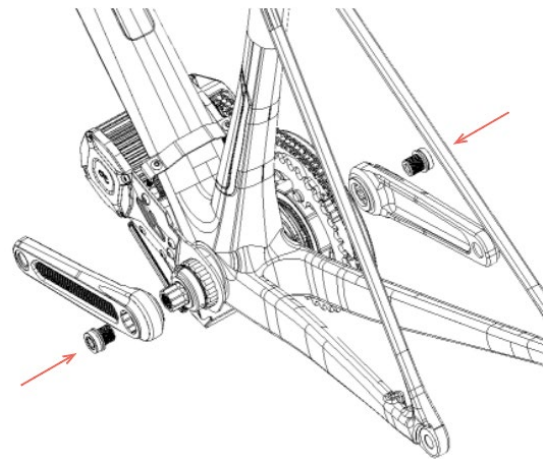
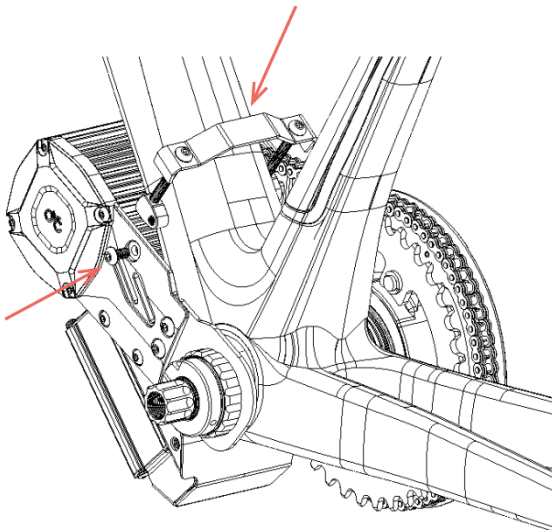

9. Add grease on spindle.
10. Place your bicycle chain over the inner chain ring. Note that you will need to undo the quick link to split your chain.
11. Connect the peripherals and your battery.
12. Test run and have fun! Use responsibly.

Installation of BB92 version

1. Insert the BB92 to BSA adapters provided to the frame's bottom bracket shell. Use a pressfit installation tool to insert the adapters.

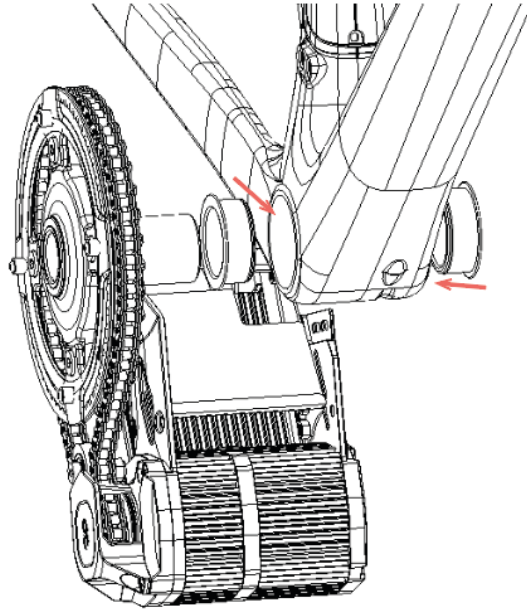

2. Line up the motor body with your frame at the bottom bracket and insert the right (drive) side of the motor into the frame's bottom bracket shell.

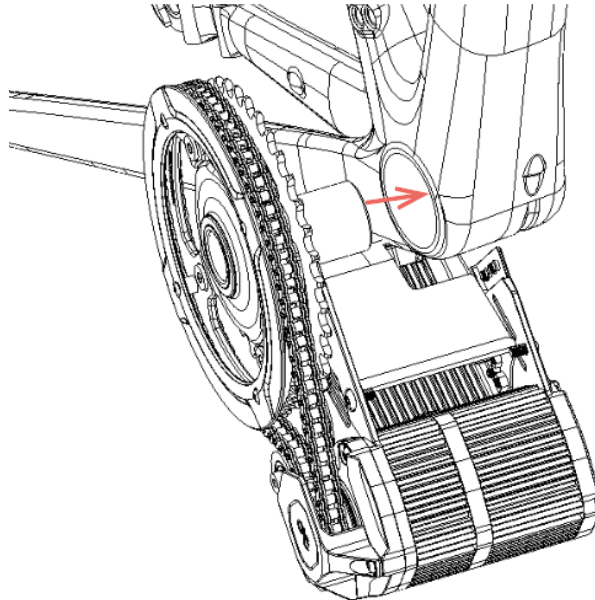

3. Add 2 x M5*6 screws into the left (non-drive) side adapter plate and the mounting bracket.

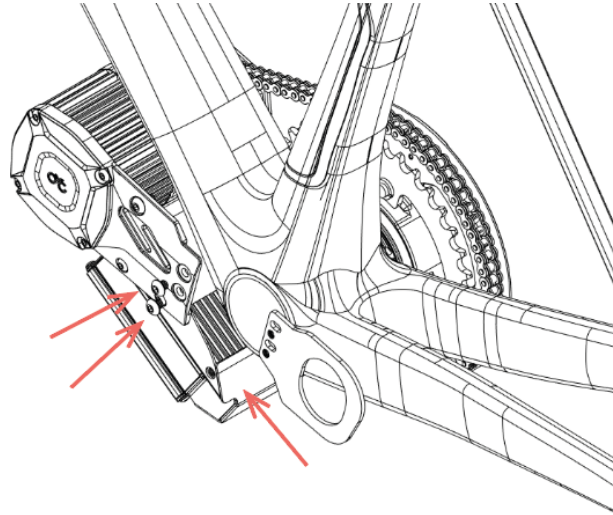

4. Add the 5mm bottom bracket spacer provided outside the adapter bracket plate on the left (non-drive) side of the frame. Thread the left (non-drive) side bottom bracket cup into the frame's bottom bracket shell through the spacer and the adapter bracket plate. Rotate clockwise.

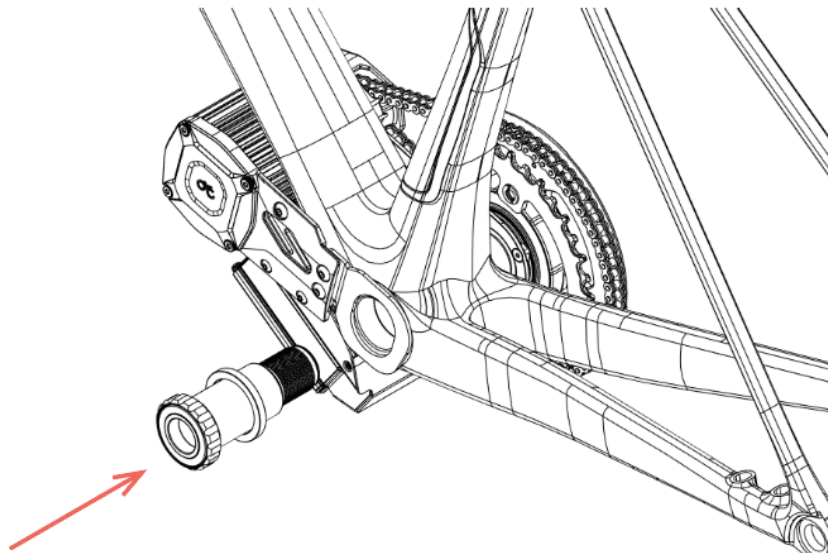

5. Insert the spindle from the right (drive) side. Note that you will need to line up the splines with the chainring assembly. If your spindle does not go through or comes to a hard stop before being fully inserted, rotate the spindle a bit and try again. Once the spindle is lined up, a soft tip hammer may also be used to get the spindle all the way through.

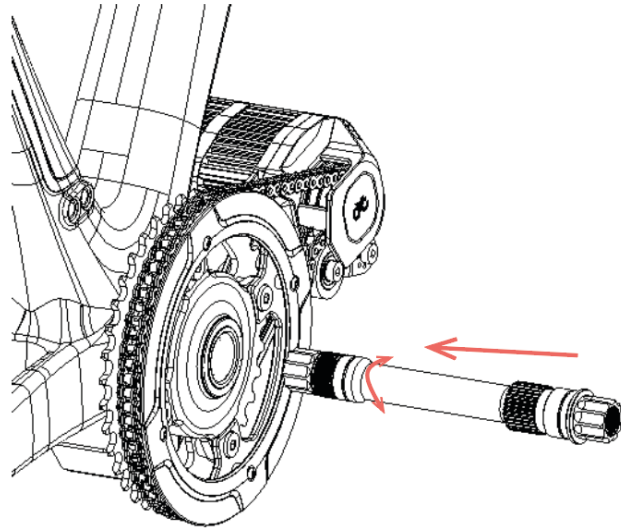

6. On the left (non-drive) side, thread in the lock ring. Use a 3mm hex key to lightly thread in the lock ring further via the small hole.

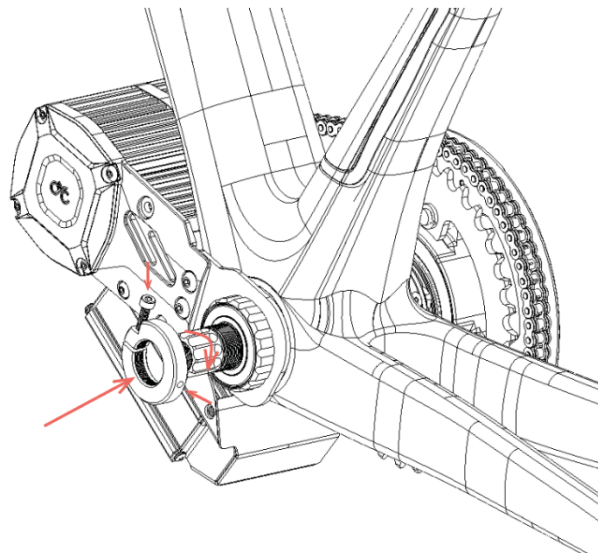

7. Install the motor hanger (see page 23) and place the rubber padding provided in between the motor and the frame.

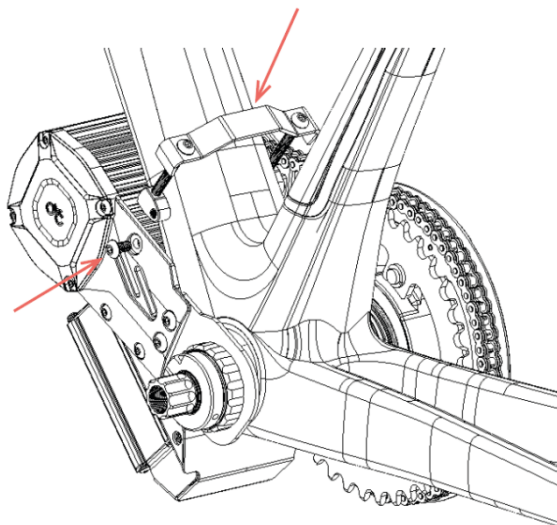



8. Insert spindle spacers on the spindle on the right (drive) side. Place the 200mm spindle in between the left (non-drive) side crank arm and the lock ring before installing the crank arms.

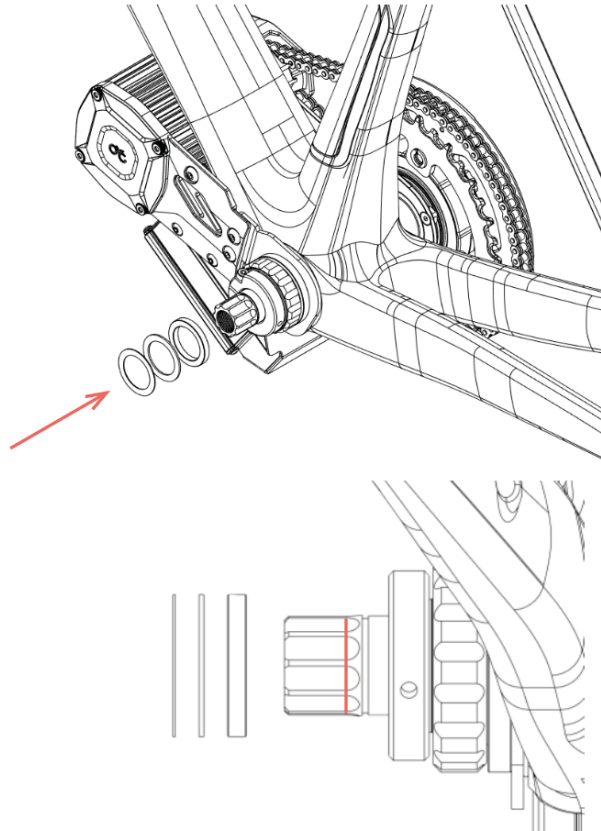

9. Install the left (non-drive) and right (drive) side crank arm according to the L and R indication on your crank arms. Use the M15 ISIS crank arm screws to tighten and secure the crank arms.

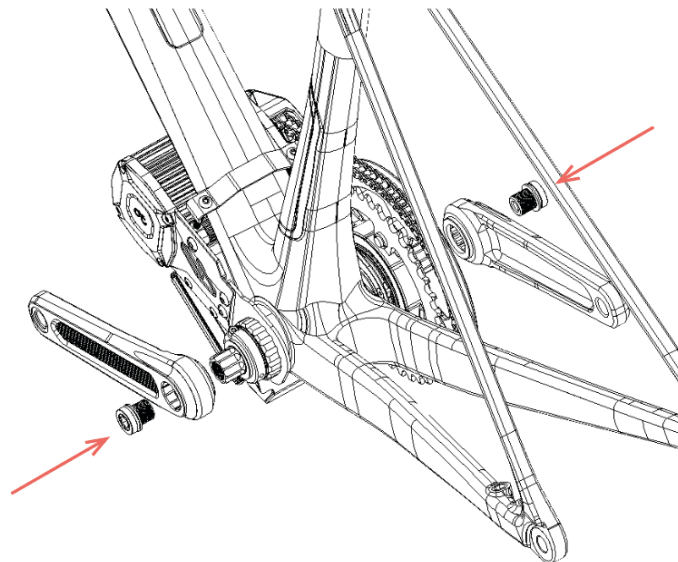

10. Place your bicycle chain over the inner chain ring. Note that you will need to undo the quick link to split your chain.
11. Connect the peripherals and your battery.
12. Test run and have fun! Use responsibly.

Mounting the Hanger

1. Place one of the aluminium joints on the inside of the bracket & screw in the bolt to attach it to the motor's mounting plate.

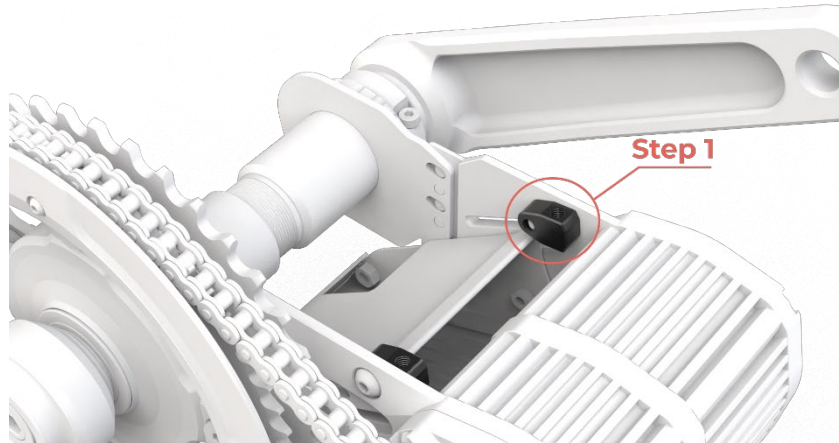

2. Position the hanger over the bike's frame & screw in the hanger to the aluminium joint loosely.

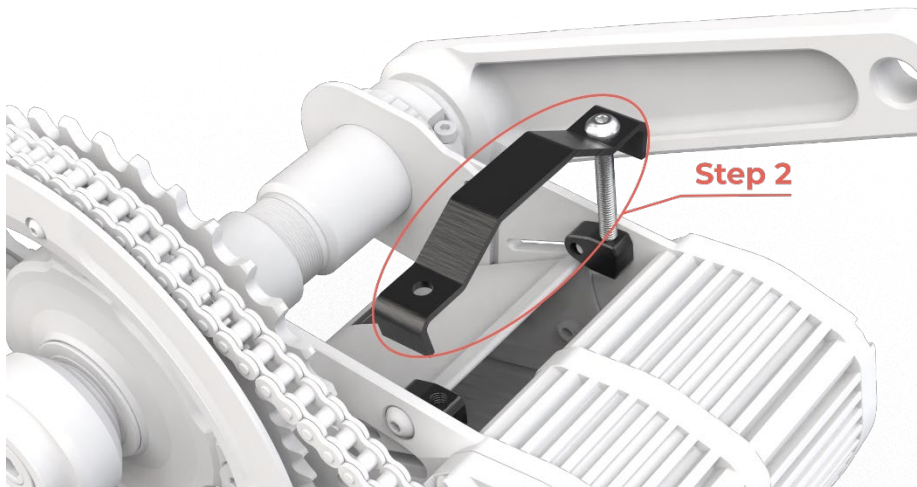



3. Insert the rubber piece provided between the frame & the bracket.

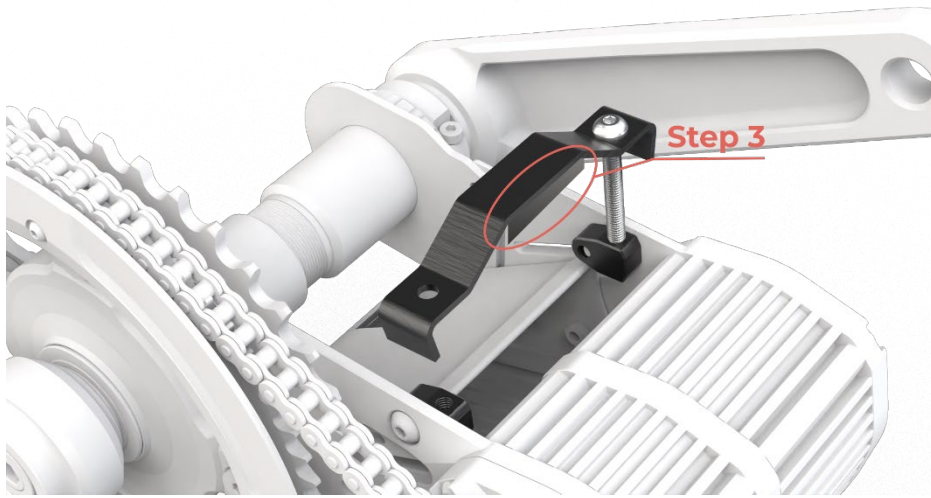

4. Place the second aluminium joint on the other side of the mounting bracket & connect the hanger fully. Tighten the hanger to ensure that the motor is secured.

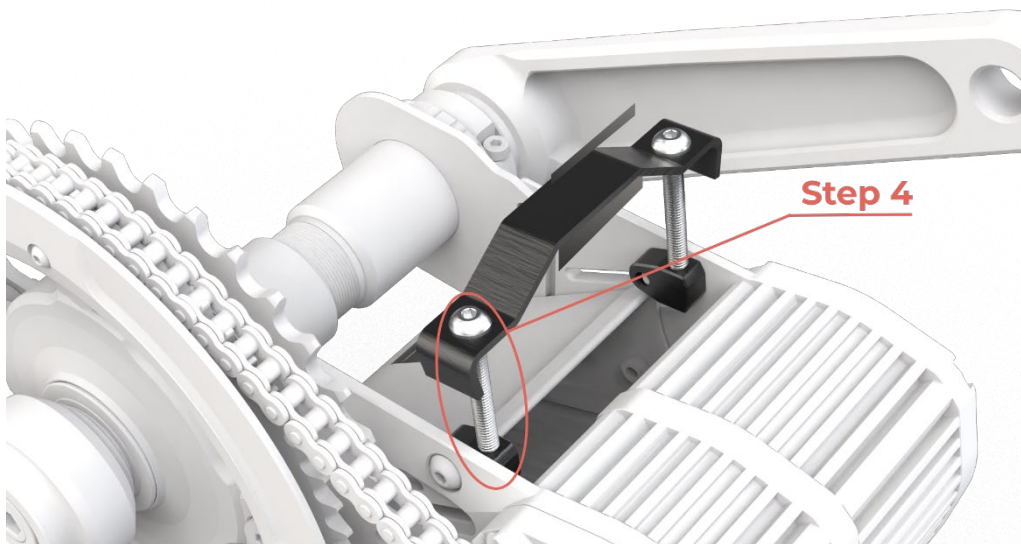



Wiring & Connection

Connect your controller to the following connectors as per below:

1. Connect the peripheral connector (P1) to the 1-2 or 1-4 wiring harness
2. Connect P2 to the speed sensor
3. P3 & P4 will already be connected when the motor is received

For brake sensors:

Please note if you purchased brake sensors separately, you will need to enable them on the CYC Ride Control app.

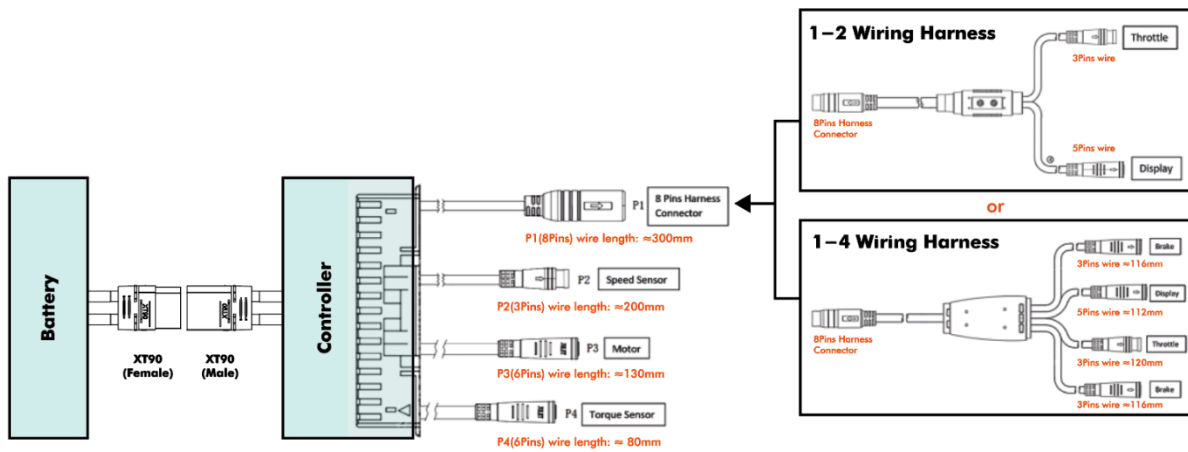

MOBILE APP & DISPLAY

Download the **display** and **mobile app** user manuals from the link below or by scanning the QR code. All materials listed below are freely available for download on our website.

<https://www.cycmotor.com/downloads>

Included in the **downloads** page:

- Instruction Card
- User Manual
- Ride Control App User Guide
- SW102 Display App User Guide
- DS103 Display User Guide
- Speed Sensor Installation Guide
- Brake Sensor Installation Guide
- 1.1 printouts for mounting reference
- And much more!





GENERAL MAINTENANCE

You are advised to regularly maintain, clean, and check the status of the bike and motor system as dirt will accumulate throughout the rides and additional strain will be taken by the drivetrain due to the powerful motor system. We recommend that users should inspect the bike and motor condition before and after each ride.

Disconnect all power supplies from the drive unit before starting any work (e.g., inspection, repair of the bike, maintenance work etc,) on the bike, transportation, or storage. Unintentional activation of the drive could lead to serious damage or injury.

Never reach into the chains, gears, or any moving parts while the bike is still in operation.

As the drive unit can get hot after use, be sure to give it some time to cool down before performing any maintenance.

Store the bike in a cool and dry place, sheltered from direct sunlight and potential rain.

Do not attempt to disassemble or modify the drive unit. The drive unit may only be repaired and maintained by qualified experts and only replaced with original spare parts. This will ensure that the safety/warranty of the drive unit is maintained.

The active moving parts (e.g., chain, gear, speed reducer etc.) should be regularly lubricated to maintain desired performance. In case of any abnormal activity, stop using the drive unit immediately and contact your CYC dealer.

Do not attempt to replace the product parts with the parts that have been found at a local bicycle store as the materials used in the drive unit are specifically designed for their purposes.

All bolts, nuts and screws are required to be tightened to the correct torque, if there is anything loose, stay off the bike. Torque specifications for each bolt and nut is provided.



Torque Requirement for Bolts

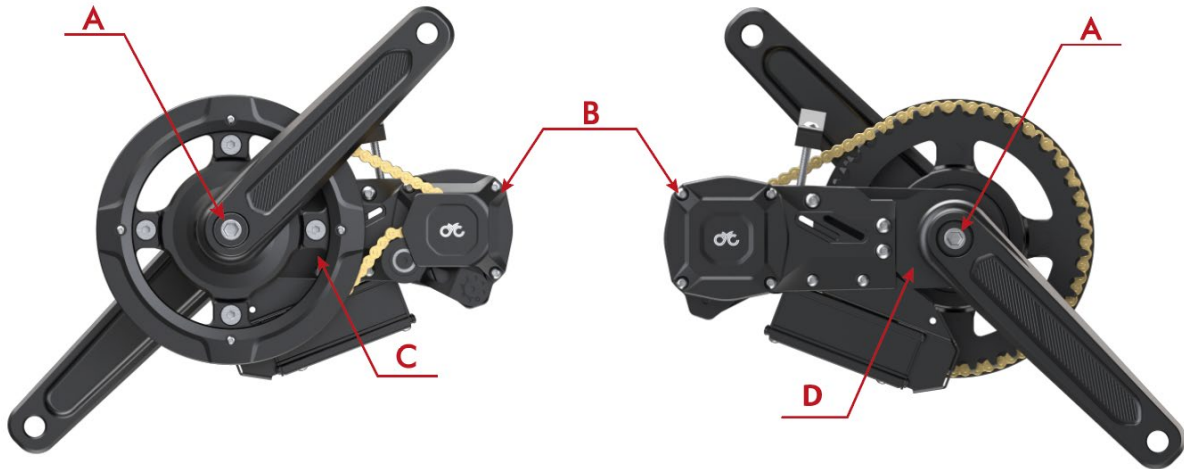

X1 Stealth Gen 3 Right View (Drive Side)

X1 Stealth Gen 3 Left View (Non-Drive Side)

Listing	Component Name	Torque Requirement
A	Crank Arm Bolts	27 – 32 N.m.
B	Motor Mounting Bolts	4 – 5 N.m.
C	Chain Ring Bolts	5 N.m.
D	Adapter Plate	4 - 5 N.m.

Bolt Specifications

Listing	Component Name	Used For	Quantity
A	M4*10 Round Hex (Silver)	Controller Mount	3
B	M4*6 Flat Head Hex (Black)	Wire Out Cover	3
C	M2*4 for Torque Sensor	Torque Sensor	4
D	M15 ISIS Crank Arm Screw	Crank Arm	2
E	M4*16 Hex Socket Head	Left Plate, C Clamp	5
F	M3*6 Cup Head Hex (Black)	X6 Controller Mount	4
G	M3*12 Cup Head Hex (Silver)	Sprocket Cover	4
H	M4*55 Round Head Bolts	Gearbox Cover	1
I	M4*60 Round Head Bolts	Gearbox Cover	1
J	M4*65 Round Head Bolts	Gearbox Cover	2
K	M5*12 Round Hex	Dice	2
L	M5*75 Round Hex	Hanger	2
M	6*12*M5 Shoulder Bolt	Tensioner	2



WARRANTY

This product has a 2-year warranty period. Man-made failures are excluded from warranty. Terms and conditions apply. Please visit www.cycmotor.com/refund-and-return-policy for more information.

For any queries or complaints, please contact us directly at support@cycmotor.com or visit our online store for replacement parts at www.cycmotor.com/shop.

PURCHASES FROM A CYC DEALER

CYC authorized dealers may have different terms and conditions. If you are experiencing any issues with your item/s and did not purchase the kit directly from us, kindly consult the appropriate dealer for assistance.

CONTACT INFORMATION

For customer support, including shipping, quotes, tax, and sales -> support@cycmotor.com

For technical assistance, including build assistance, recommendations, troubleshooting, and product related queries -> technical_support@cycmotor.com.

OFFICE HOURS

Monday to Friday

9AM – 6PM (Hong Kong Time HKT)



DISCLAIMER

The electric bicycle system described in this user manual is designed for converting a bicycle only. It is important to read and understand this manual before using the system.

The manufacturer of this electric bicycle system will not be held liable for any direct, indirect, incidental, or consequential damages that might arise from the use or misuse of this system. Users are solely responsible for their safety while operating their electric bicycles and assume all risks associated with the use of this system.

PRIVACY POLICY

CYC MOTOR LTD strives to provide the best ebike & emtb experiences through our mid-drive electric bike conversion kits, adhering to the highest standards of industry ethics. We encourage you to read our Privacy Policy for more details.

CYC MOTOR LTD developed the CYC MOTOR LTD apps, including the RISTRETTO 303 FS and CYC Motor (BAC) app, as free services. These services are provided by CYC MOTOR LTD at no cost and are designed for use 'as is.' The RISTRETTO 303 FS and CYC Motor (BAC) apps gather location data to facilitate Bluetooth device searching following the ASI controller's protocol. Please note that we do not upload or track your location data.

This page aims to inform visitors about our policies concerning the collection, use, and disclosure of Personal Information for those who decide to use our Service.

By choosing to use our Service, you consent to the collection and use of information in accordance with this policy. The Personal Information we gather is employed for providing and enhancing the Service. We will not use or share your information with anyone except as described in this Privacy Policy.

The terms in this Privacy Policy have the same meanings as in our Terms and Conditions, accessible at CYC MOTOR LTD, unless otherwise specified in this Privacy Policy.

INFORMATION AND COLLECTION USE

To enhance your experience while using our Service, we may need you to provide us with certain personally identifiable information, such as your name (optional), phone number, email address, and location (optional). This information, once collected, will be retained, and utilized as outlined in this privacy policy. Please be aware that our app uses third-party services that may collect information used to identify you.



Please visit www.cycmotor.com/privacy-policy for more detailed information.